

## SPOUT

### Rough Installation For Spout

Hole size for the spout shank and handle valves are minimum of 1 1/4" and maximum of 1 1/2".

Remove tee connector and spout mounting hardware from spout shank.

Apply a ring of silicone caulking around hole designated for spout.

**IMPORTANT:** Find the "Front Here" mark, which is marked on the spout shank, and make sure that it is facing forward.

Slip spout shank through deck top and reattach the spout mounting hardware until secure.

Wipe away excess silicone with paper towel.

Wrap the bottom threads with teflon tape and thread the tee connector back onto spout shank.

Fit spout shank cap over the spout shank until trim arrives.

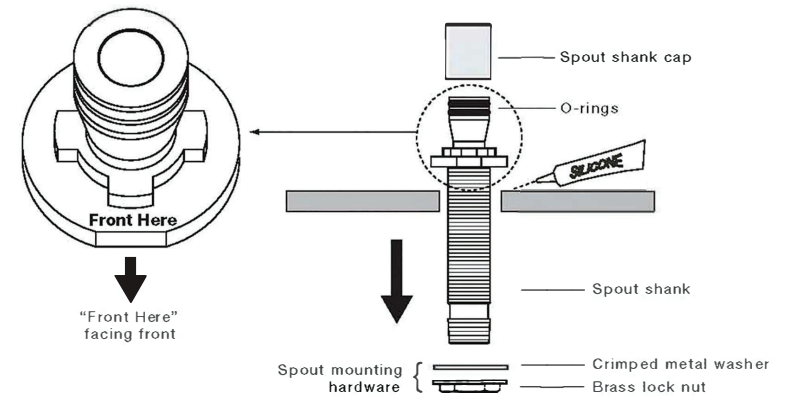

# HANDLE

## Rough Installation For Handle

NOTE: Hot valve "Red" mounted to left side. Cold valve "Blue" to be mounted on right side.

Remove the top mounting lock nut and rubber washer from the valve body.

NOTE: Fiber washer and bottom lock nut should be loose when securing the top mounting lock nut and rubber washer.

Apply a ring of silicone around the handle hole on top of the deck.

Slip the valve body into the proper handle hole from underneath the tub. Thread the top mounting lock nut and rubber washer back onto the valve body and tighten down securely.

NOTE: While tightening the valve body into place make sure to keep the position of the valve body outlet pointed toward the tee connector.

From underneath, tighten the bottom lock nut securely.

Fit valve cover onto the valve until trim arrives.

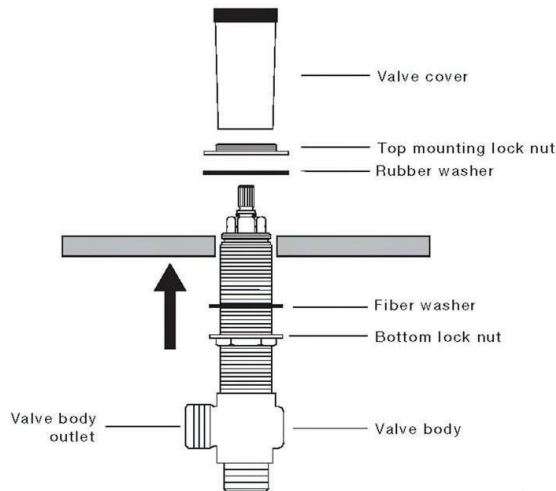

# Installation Instructions

Flush both supply lines before installation. After flushing, shut off both supply lines.

Hole size for the spout and handle trim is a minimum of 1¼" and a maximum of 1½".

## 1. Diverter Installation

Unscrew the pre-assembled diverter base ring from the diverter.

Slip the diverter valve body up from the bottom of the tub through the appropriate hole. From tub top, screw base ring back onto the diverter.

Tighten the lock nut firmly.

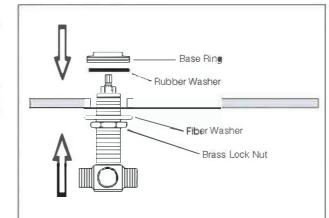

## 2. Handle Shower Installation

Take the lock nut and metal washer off the flange mount.

From the tub top, slip the flange mount down through the appropriate hole.

Reinsert the mounting hardware from the bottom of the tub, first the crimped metal washer, then the brass nut.

Tighten the lock nut firmly.

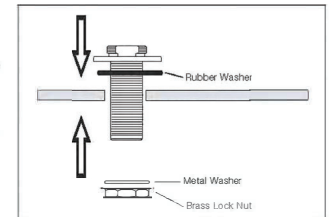

From underneath the tub, screw the 1/2" female hose with the rubber washer onto the diverter's outlet. Tighten it firmly.

Slip the other end of the hose up through the guide tube.

DO NOT TAKE THE RUBBER WASHER AND RED WASHER OFF, UNLESS THE UNIT IS READY FOR TRIM INSTALLATION.

Slip the vinyl pull-tab cap onto the 3/8" side of the hose. Make sure cap is firmly inserted onto the hose's coupler.

DO NOT TAKE THE CAP OFF UNLESS THE UNIT IS READY FOR TRIM INSTALLATION.

BOTH PULL-TAB CAP AND THE RUBBER BAND WITH THE WASHERS WILL HELP TO PREVENT THE HOSE FROM SLIPPING DOWN UNDERNEATH THE TUB.

