

Please read the instructions completely before beginning the installation.

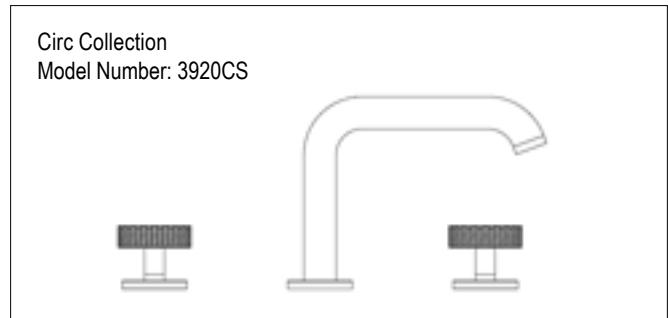
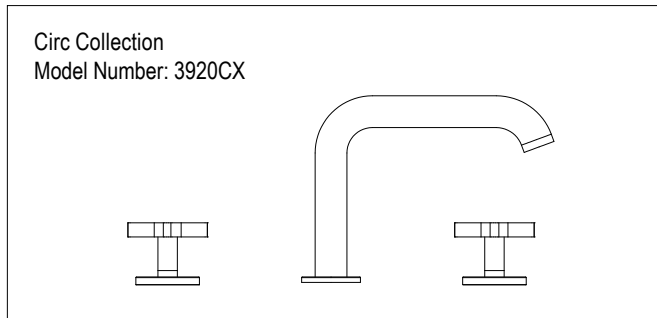
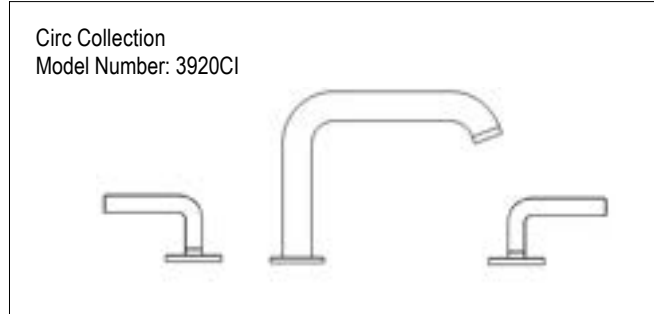

Flush both supply lines before installation, then shut off both supply lines.
Minimum hole size for the spout and handle trim is 1-1/4" and maximum of 1-1/2"

The measurements shown are for reference only. Products and specifications shown are subject to change without notice.

SPOUT INSTALLATION

1 - Remove the tee connector, spout mounting hardware and tee connector washer from the bottom of the spout assembly. Apply a ring of silicon caulking around the center hole on the top of the sink. Do not use plumbers' putty which can damage the finish of the faucet. - From the top of the deck, insert the spout's threaded shank through the center hole of the sink. Make sure the spout flange washer is properly placed underneath of the flange and gently pressed against the sink top.

2 - Slip the spout mounting hardware back onto the spout. First the notched rubber washer, then the notched metal washer, followed by the wing nut, and lastly the brass lock nut. Hand tighten the lock nut. Secure spout by tightening the two screws on wing nut. - Tighten the lock nut. Make sure the spout does not move side ways Adjust it if necessary. - Place the tee connector washer into the tee connector and thread the tee connector onto the end of the spout shank. Tighten to seal. - Align the spout and tighten the shank lock nut firmly.

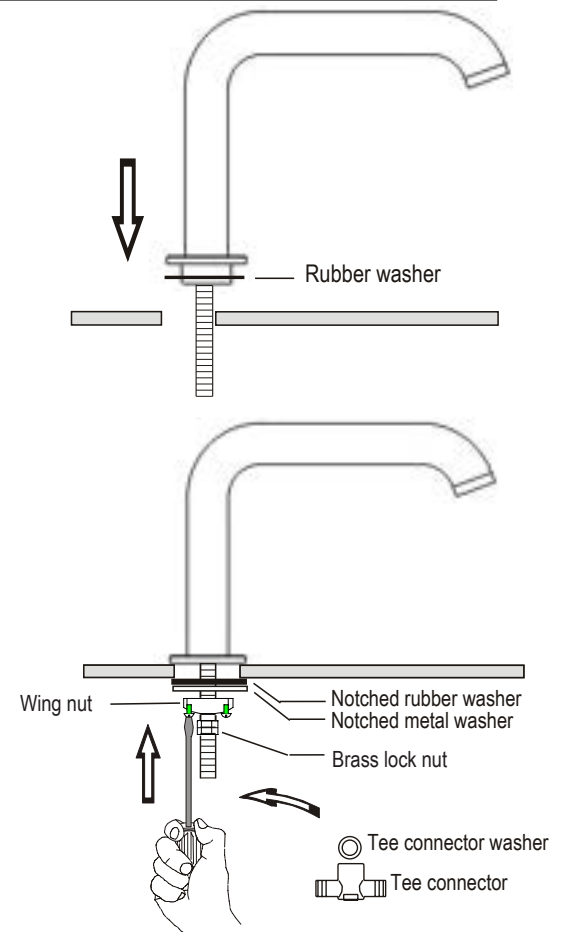

HANDLE TRIM INSTALLATION

DO NOT DISASSEMBLE HANDLE ASSEMBLY - DROP-IN VALVES

1 - Both hot and cold side handle trims are pre-assembled for faster installation.

- For proper handle turning direction, install the handle with the “cold” blue label at the right side of the spout (looking from the front) and the handle with “hot” red label at the left side of the spout.
- Remove the valve body mounting hardware from the valve body. Slip the valve body’s flexible hoses from the top of the sink or counter through the appropriate hole next to the spout. Make sure the handle flange washer is properly placed underneath of the flange and gently pressed against the sink top. Aim the tee connecting hoses toward the tee connector.

2 - Under the sink, place the rubber washer into the valve body, then the metal washer, and lastly the brass lock nut.

- Align the handle lever or cross handle properly against the spout. Tighten the lock nut until it secures the valve body firmly. The security screw can be tightened if needed.

3 - Connect the flexible hoses to the tee. Tighten to avoid the leakage.

- Connect and tighten the Inlet hoses to the supply lines.
- After the connections have been made, turn on the water supply and check for leakages at all joints. If water leaks from any of the connections tighten the connection until the leakage stops.
- If no leakage, turn the handles to the full open position and let the water flush for about 45 seconds. This can prevent damages to the ceramic cartridges caused by debris in the supply line.
- During the flushing, check for leakage at the connecting joints and repeat step 3 if necessary.

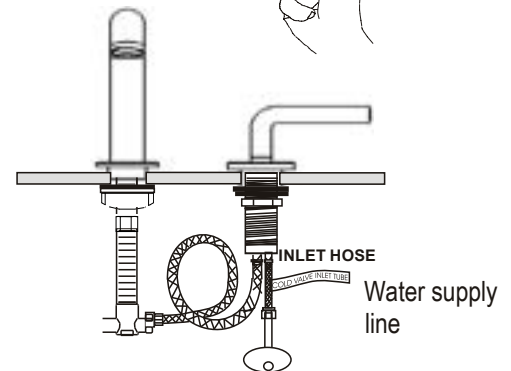
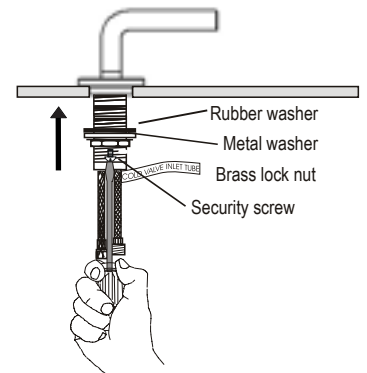
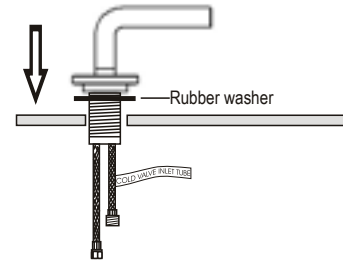

COMPLETE ASSEMBLY

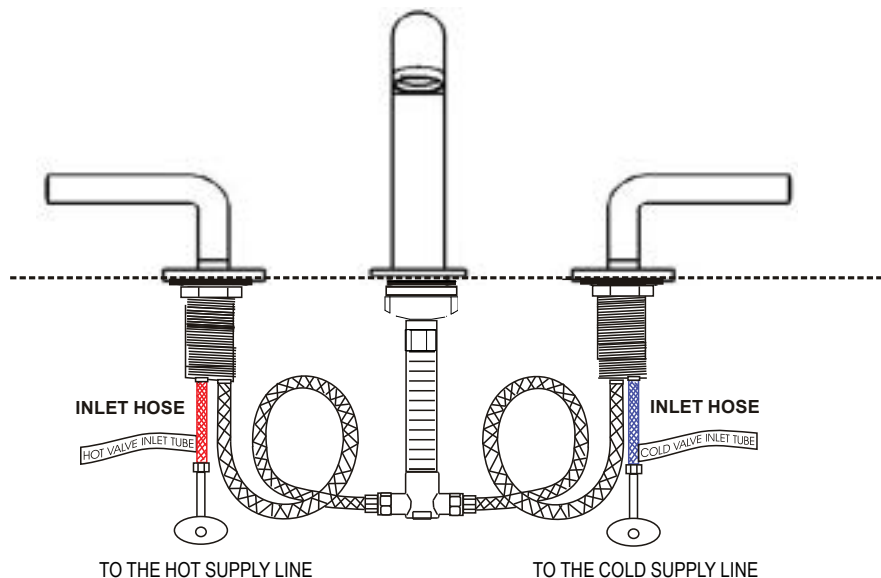

The measurements shown are for reference only. Products and specifications shown are subject to change without notice.

PUSH POP-UP INSTALLATION

- 1 Remove the drain plug and gasket from push pop-up assembly. remove the washer, lock nut and un-thread bottom drain tube.
- 2 Insert flange on the drain hole up through bottom of lavatory. add silicon sealant/putty around the flange. Secure by adding rubber washer, gasket, plastic washer and lock nut.
- 3 Insert the threaded end of the assembly up from the under the sink so that the drain tube is firmly attached to the drain plug.. Make sure to add plumber tape before threading the drain tube.
- 4 Make sure the thread of drain flange and bottom of the drain tube are tighten. If not it may cause water leaks. add tape or tighten the locknut from under the sink.
- 5 Test the push pop-up for smooth operation. to open push pop-up simply push once. Push again to close it.

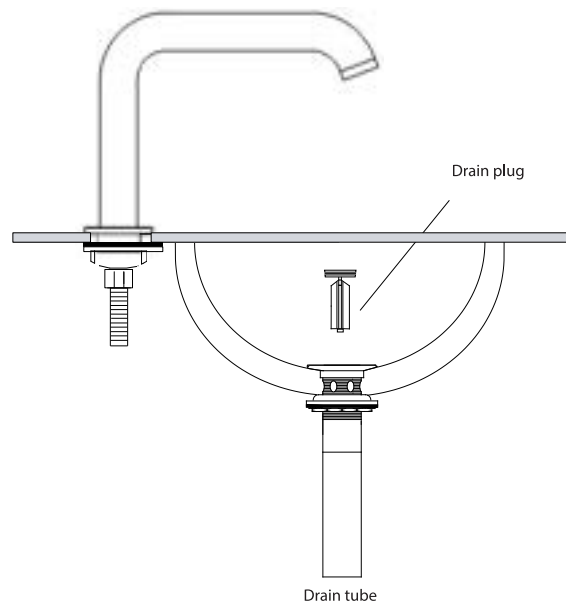
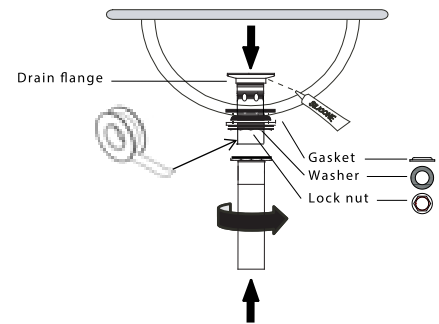
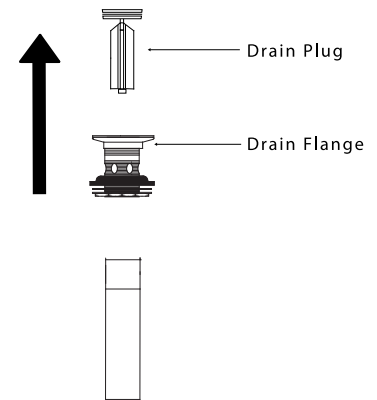

The measurements shown are for reference only. Products and specifications shown are subject to change without notice.