

SPOUT

Rough Installation For Spout

Hole size for the spout shank and handle valves are minimum of 1¼” and maximum of 1½”.

Remove tee connector and spout mounting hardware from spout shank.

Apply a ring of silicone caulking around hole designated for spout.

IMPORTANT: Find the “Front Here” mark, which is marked on the spout shank, and make sure that it is facing forward.

Slip spout shank through deck top and reattach the spout mounting hardware until secure.

Wipe away excess silicone with paper towel.

Wrap the bottom threads with teflon tape and thread the tee connector back onto spout shank.

Fit spout shank cap over the spout shank until trim arrives.

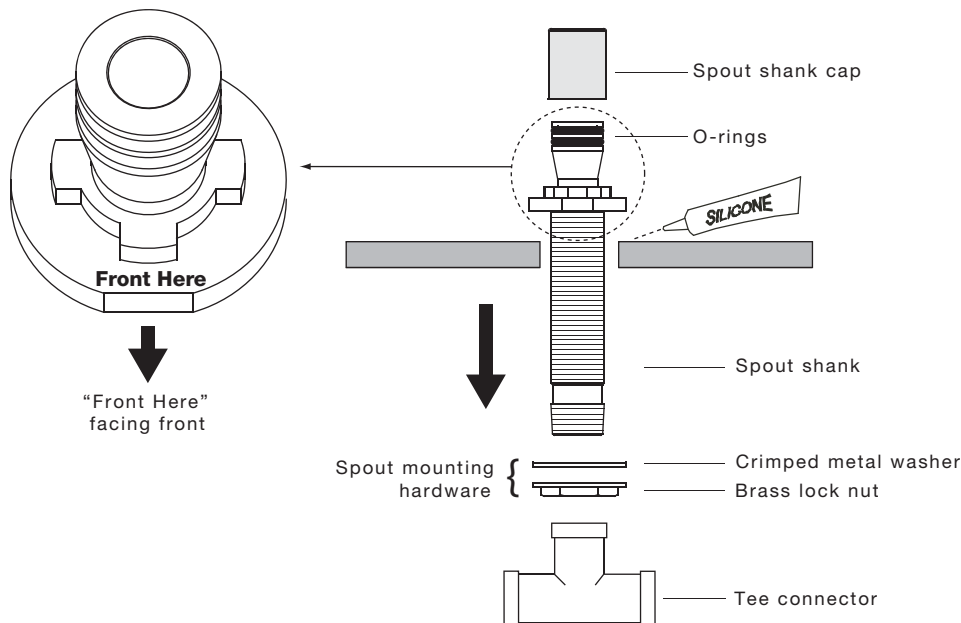

HANDLE

Rough Installation For Handle

NOTE: Hot valve “Red” mounted to left side. Cold valve “Blue” to be mounted on right side.

Remove the flange sleeve adapter and rubber washer from the valve body.

NOTE: Fiber washer, brass tube, and bottom lock nut should be loose when securing the flange sleeve adapter and rubber washer.

Apply a ring of silicone around the handle hole on top of the deck.

Slip the valve body into the proper handle hole from underneath the tub. Thread the flange sleeve adapter and rubber washer back onto the valve body and tighten down securely.

NOTE: While tightening the valve body into place make sure to keep the position of the valve body outlet pointed toward the tee connector.

From underneath, tighten the bottom lock nut securely.

Fit valve cover onto the valve until trim arrives.

