

KEEP THIS INSTRUCTION BOOKLET FOR FUTURE REFERENCE

Important : Please register your product online at www.santecfaucet.com within 30 days of purchase. Santec reserves the right to request additional documents before servicing warranty requests.

Specifications

Description

This product is precision engineered to provide satisfactory performance provided it is installed and operated in accordance with our recommendations contained in this manual. In order to fully enjoy the comfort, safety and the reliability of your pressure balancing valve, be certain to familiarize yourself with the contents of this manual.

Specification and Dimensions

- Minimum operating pressure 20 psi
- Maximum operating pressure 145 psi
- Maximum test pressure 500 psi
- Hot and cold water inlets 1/2" IPS
- Shower outlet 1/2" IPS
- Flow capacity 5 USGPM @ 50 psi
- Finished wall adjustment : See Figure 1

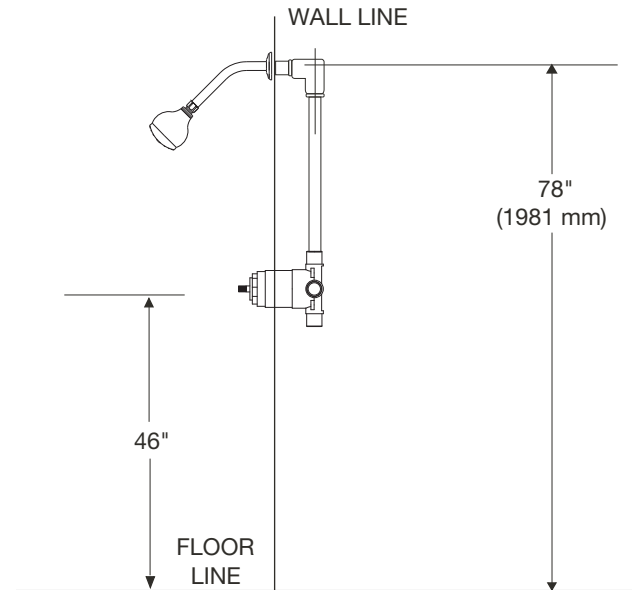

Pressure Balanced Shower Valve

1. Rough-in & Valve Installation

NOTE: Failure to follow these instructions may cause damage or improper operations and nullify the warranty.

1. Make sure the water supplies are off.
2. Rough valve body into wall, connecting piping to 1/2" female copper sockets or 1/2" male I.P. nipples. **IMPORTANT: NOTE "UP" & "DOWN" MARKINGS ON BACK OF VALVE.**
3. The depth of rough-in should account for thickness of wall materials to be used (combined thickness of wall board and finished wall material). **The distance between the center inlet of the valve and the finished wall should be between 1 5/8" and 2"**. Face of plastic guard should be flush with finished wall (see Figure 1).
4. Anchor installation to bracing between studs (ears on the valve body can be used for this by removing the plastic guard) - otherwise, anchor the connecting pipe.
5. Valve should be pressurized and tested for leaks at the connections.
6. Plastic guard should be left attached to the valve until the finished wall material is installed and until the trim arrives to be installed.

FIGURE 1

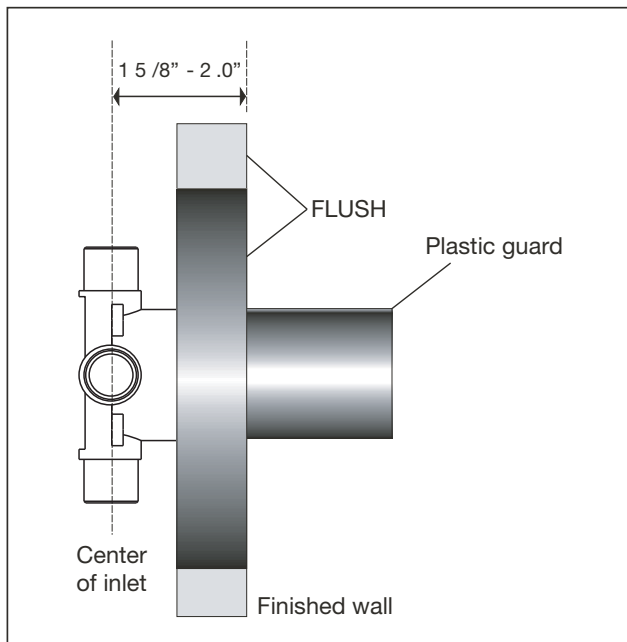

Pressure Balanced Shower Valve

2. Reversing the Cartridge

When a valve is installed with reversed supply connections, the cartridge can be reversed to allow normal operation (see Figure 2).

1. Remove the trim sleeve to expose top of valve.
2. Loosen and remove hex nut above cartridge.
3. Remove cartridge from valve cavity.
4. Look into cavity to see upper and lower locating holes for cartridge pin on the floor of the cavity.
5. Re-insert cartridge, aligning the pin with lower locating hole (partially cut away by discharge opening).
6. Press cartridge in firmly to assure that pin has been properly inserted.
7. Secure cartridge by tightly reassembling the hex nut.
8. Reassemble trim.

FIGURE 2

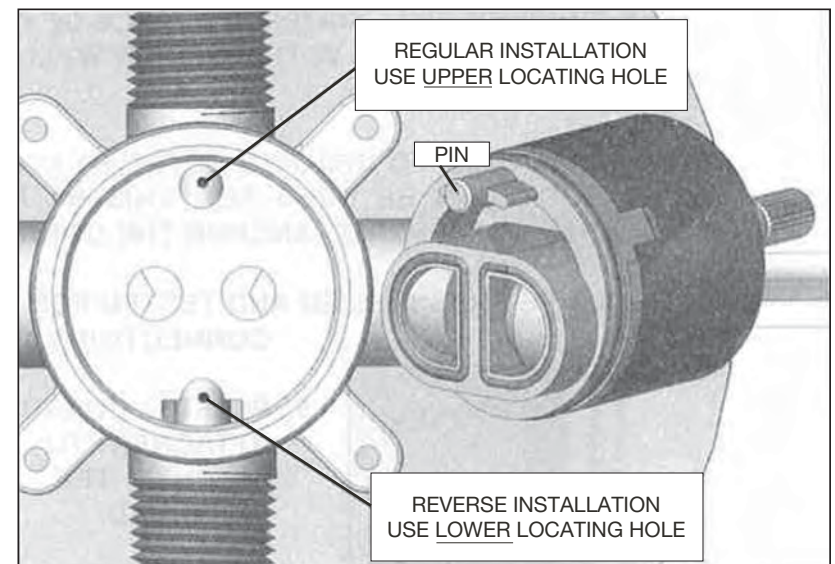

Pressure Balanced Shower Valve

2. Setting Hot Limit: IMPORTANT!!

THE REMOVAL OF THE WARNING LABEL BARRIER ON THE FACE OF THIS MIXING VALVE CONSTITUTES THE TRANSFER OF LIABILITY FROM THE MANUFACTURER TO THE INSTALLER UNDER THE LAWS OF THE UNITED STATES. IT IS THE INSTALLERS RESPONSIBILITY TO SET THE MAXIMUM OUTPUT TEMPERATURE OF THE VALVE TO NO MORE THAN 120F, IN ACCORDANCE WITH ASSE/ANSI STANDARD 1016-1996 DEALING WITH INDIVIDUAL THERMOSTATIC, PRESSURE BALANCING AND COMBINATION PRESSURE BALANCING AND THERMOSTATIC CONTROL VALVES FOR INDIVIDUAL FIXTURES SECTION 4.2.2., TEMPERATURE LIMIT SETTING.

TO PROPERLY SET THE LIMIT RING, YOU MUST USE A THERMOMETER OR CALIBRATED SENSING DEVICE TO ACCURATELY MEASURE THE OUTLET WATER TEMPERATURE. THE ADJUSTMENT RING IS POSITIONED AS FOLLOWS:

1. Expose the top of the cartridge by removing the trim sleeve from the valve body. Do **not** remove the hex nut holding it in place.
2. Remove the grey adjustment ring by placing the blade of a knife into the groove and prying it off (**see Figure 3**).
3. Note the stop on the bottom of the ring (**see Figure 4**). The further it is re-oriented in a counter-clockwise direction, the shorter the travel allowed (and thus, the lower the temperature output possible).

IMPORTANT: BEFORE RE-ORIENTING THE RING, BE SURE THE STEM IS IN THE FULL OFF POSITION.

FIGURE 3

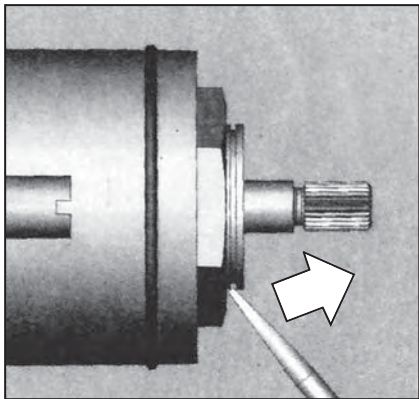

FIGURE 4

